

MENIIT

NEET | IIT-JEE | FOUNDATION

Corporate Office: 44-A/1, Kalu Sarai, New Delhi 110016 | Web: www.meniit.com

JEE MAINS-2019

09-04-2019 Online (Evening)

IMPORTANT INSTRUCTIONS

1. The test is of 3 hours duration.
2. This Test Paper consists of **90 questions**. The maximum marks are 360.
3. There are three parts in the question paper A, B, C consisting of **Chemistry, Mathematics and Physics** having 30 questions in each part of equal weightage. Each question is allotted 4 (four) marks for correct response.
4. Out of the four options given for each question, only one option is the correct answer.
5. For each incorrect response 1 mark i.e. $\frac{1}{4}$ (one-fourth) marks of the total marks allotted to the question will be deducted from the total score. No deduction from the total score, however, will be made if no response is indicated for an item in the Answer Box.
6. Candidates will be awarded marks as stated above in instruction No.3 for correct response of each question. One mark will be deducted for indicating incorrect response of each question. No deduction from the total score will be made if no response is indicated for an item in the answer box.
7. There is only one correct response for each question. Marked up more than one response in any question will be treated as wrong response and marked up for wrong response will be deducted accordingly as per instruction 6 above.

PART-A-CHEMISTRY

1. Increasing order of reactivity of the following compounds for S_N1 substitution is:

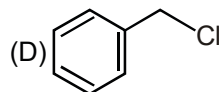
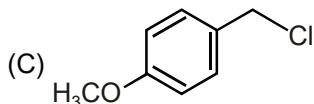
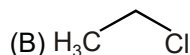
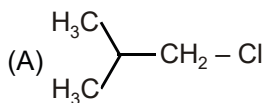

(1) (A) < (B) < (D) < (C)

(2) (B) < (C) < (A) < (D)

(3) (B) < (C) < (D) < (A)

(4*) (B) < (A) < (D) < (C)

Sol. Stability of carbonium ions involved in the reaction follow the order;

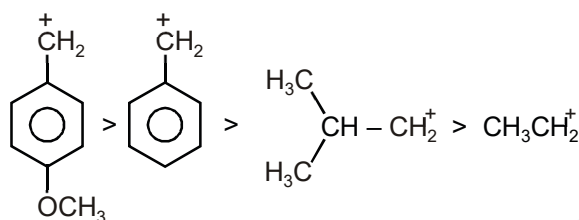

∴ Reactivity a Stability of carbonium ion

2. Molal depression constant for a solvent is $4.0 \text{ K kg mol}^{-1}$. The depression in the freezing point of the solvent for 0.03 mol kg^{-1} solution of K_2SO_4 is :

(Assume complete dissociation of the electrolyte)

(1) 0.24 K

(2) 0.18 K

(3*) 0.36 K

(4) 0.12 K

Sol. $K_f = 4 \text{ K Kg mol}^{-1}$

$i = 3$

Molality = 0.03

$\Delta T_f = i K_f m$

= 3(4) (0.03)

$\Delta T_f = 0.36 \text{ K}$

3. Which of the following compounds is a constituent of the polymer?

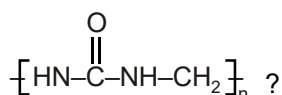

(1*) Formaldehyde

(2) N-Methyl urea

(3) Methylamine

(4) Ammonia

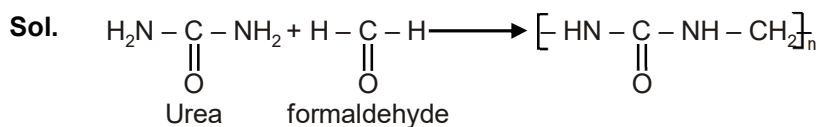

4. Consider the given plot of enthalpy of the following reaction between A and B.



Identify the incorrect statement.

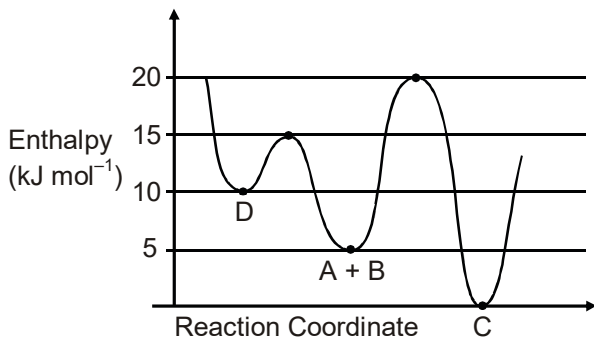

- (1) Formation of A and B from C has highest enthalpy of activation.
- (2) C is the thermodynamically stable product.
- (3) D is kinetically stable product.
- (4*) Activation enthalpy to form C is 5 kJ mol^{-1} less than that to form D.

Sol. $E_a = (D \rightarrow C)$

$$= 15 - 0 = 15 \text{ kJ mol}^{-1}$$

$$E_a = (A + B) \rightarrow C = 15 \text{ kJ mol}^{-1}$$

$$E_a = (A + B) \rightarrow D = 10 \text{ kJ mol}^{-1}$$

$$E_a = C \rightarrow (A + B) = 20 \text{ kJ mol}^{-1} \text{ (high activation enthalpy in the reaction)}$$

\therefore Activation enthalpy to form C is 5 kJ mol^{-1} more than that of form D.

5. At a given temperature T, gases Ne, Ar, Xe and Kr are found to deviate from ideal gas behaviour. Their

equation of state is given as $p = \frac{RT}{V-b}$ at T.

Here, b is the van der Waals constant. Which gas will exhibit steepest increase in the plot of Z (compression factor) vs p?

- (1) Ar
- (2) Kr
- (3*) Xe
- (4) Ne

Sol. $P = \frac{RT}{(V-b)}$

$$P(V-b) = RT$$

$$\left(P + \frac{a}{V^2}\right)(V-b) = RT$$

At high pressure.

$$P(V-b) = RT$$

$$PV - Pb = RT$$

$$\frac{PV}{RT} - \frac{Pb}{RT} = 1$$

$$Z = 1 + \frac{Pb}{RT}$$

$$Z > 1, z \propto \beta$$

The value of 'b' for the gases follows the order

$$Ne < Ar < Kr < Xe$$

6. The maximum possible denticities of a ligand given below towards a common transition and inner-transition metal ion, respectively, are :

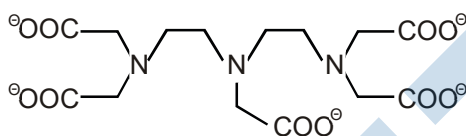

- (1) 8 and 8 (2) 6 and 6 (3) 8 and 6 (4*) 6 and 8

Sol. General coordination number of CN^- in transition element is 6 and in inner transition element is 8-12. because inner transition metal ions can make available more number of vacant orbitals of nearly same energy than transition metal ions. The high effective nuclear charge of inner-transition metal ions make them form complex with high coordination number.

7. HF has highest boiling point among hydrogen halides, because it has :

- (1*) strongest hydrogen bonding (2) lowest dissociation enthalpy
 (3) lowest ionic character (4) strongest van der Waals' interactions

Sol. HF has strong hydrogen bond \therefore It has highest boiling point among hydrogen halides. The strong hydrogen bond is due to more difference in electronegativity between F and H atoms.

8. What would be the molality of 20% (mass/ mass) aqueous solution of KI?

(molar mass of KI = 166 g mol⁻¹)

- (1) 1.48 (2) 1.08 (3*) 1.51 (4) 1.35

Sol. 20% w/w KI

Mass of solute(KI) = 20 g

Mass of solvent = 100 – 20 = 80 g

Molar mass of KI = 38 + 128 = 166

$$\text{Molality} = \frac{\text{gm(solute)}}{\text{mw} \times \text{Kg(solvent)}} = \frac{20 \times 1000}{166 \times 80} = 1.506 = 1.51$$

9. The amorphous form of silica is :

- (1) tridymite (2*) kieselguhr (3) cristobalite (4) quartz

Sol. Kieselguhr is amorphous form of silica.

10. Noradrenaline is a /an -

- (1) Antacid (2) Antidepressant (3) Antihistamine (4*) Neurotransmitter

Sol. It is an organic chemical in the catecholamine family that functions in the brain and body as hormone and neurotransmitter.

11. Hinsberg's reagent is :

- (1) C₆H₅COCl (2) (COCl)₂ (3*) C₆H₅SO₂Cl (4) SOCl₂

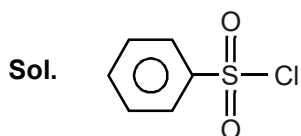

12. p-Hydroxy benzophenone upon reaction with bromine in carbon tetrachloride gives:

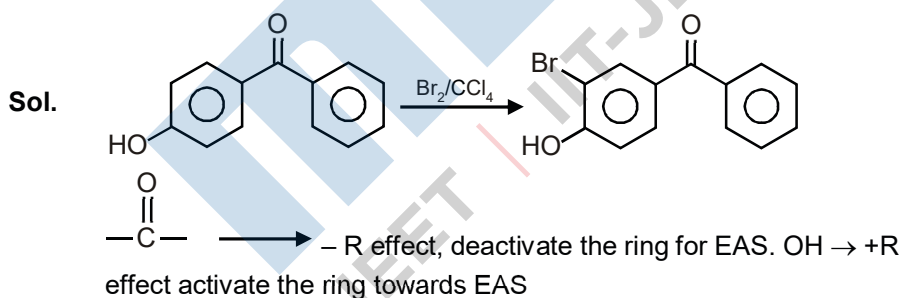
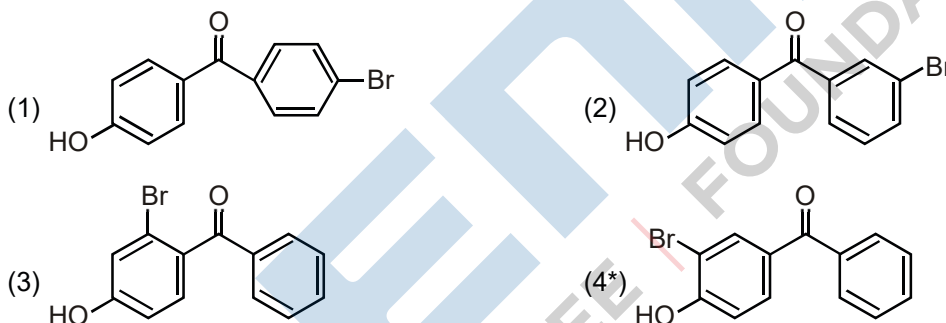

13. A solution of Ni(NO₃)₂ is electrolysed between platinum electrodes using 0.1 Faraday electricity. How many mole of Ni will be deposited at the cathode?

- (1) 0.10 (2) 0.15 (3*) 0.05 (4) 0.20

Sol. 1F deposits 1 g equivalent of Ni or ½ mole of Ni

∴ 0.1 F will deposit $\frac{1}{20} = 0.05$ moles of Ni

14. The one that is not a carbonate ore is :

- (1*) bauxite (2) calamine (3) siderite (4) malachite

Sol. Malachite = $\text{CuCO}_3 \cdot \text{Cu(OH)}_2$

Bauxite = $\text{Al}_2\text{O}_3 \cdot 2\text{H}_2\text{O}$

Calamine = ZnCO_3

Siderite = FeCO_3

15. The peptide that gives positive ceric ammonium nitrate and carbylamines tests is :

- (1*) Ser-Lys (2) Asp-Gln (3) Gln-Asp (4) Lys-Asp

Sol. Due to $-\text{OH}$ group of serine it give ceric ammonium nitrate test whereas due to $-\text{NH}_2$ group lysine give +ve carbylamine test

16. The **correct** statements among I to III are :

- (I) Valence bond theory cannot explain the color exhibited by transition metal complexes.
 (II) Valence bond theory can predict quantitatively the magnetic properties of transition metal complexes.
 (III) Valence bond theory cannot distinguish ligands as weak and strong field ones.

- (1*) (I) and (III) only (2) (I) and (II) only (3) (II) and (III) only (4) (I), (II) and (III)

Sol. (i) VBT does not explain colour exhibited by complex of transition metal because splitting of d-orbitals in explained by CFT.

(ii) VBT does not distinguish between strong and weak field complex.

(iii) VBT does not give quantitative interpretation of magnetic properties.

\therefore According to question statement I and III are correct.

17. In the following reaction

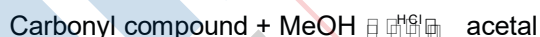

Rate of the reaction is the highest for :

- (1) Propanal as substrate and methanol in stoichiometric amount.
 (2*) Propanal as substrate and methanol in excess
 (3) Acetone as substrate and methanol in excess
 (4) Acetone as substrate and methanol in stoichiometric amount

Sol. Ketones < Aldehyde \longrightarrow Rate of Nucleophilic addition reaction

Only aldehydes are responsible for formation of acetals. Excess of MeOH is used to drive the reaction towards forward direction.

18. **Assertion** : For the extraction of iron, hematite ore is used.

Reason : Hematite is a carbonate ore of iron.

- (1) Only the reason is correct.
- (2) Both the assertion and reason are correct, but the reason is not the correct explanation for the assertion.
- (3) Both the assertion and reason are correct and the reason is the correct explanation for the assertion.
- (4*) Only the assertion is correct.

Sol. Extraction of Fe is done form hematite ore this is true but reason is wrong as hematite is Fe_2O_3 .

19. Which one of the following about an electron occupying the 1s orbital in a hydrogen atom is incorrect ?
(The Bohr radius is represented by a_0)

- (1) The electron can be found at a distance $2a_0$ from the nucleus
- (2) The probability density of finding the electron is maximum at the nucleus.
- (3) The magnitude of the potential energy is double that of its kinetic energy on an average.
- (4*) The total energy of the electron is maximum when it is at a distance a_0 from the nucleus.

Sol. $T.E = -K.E = \frac{PE}{2}$

The energy of electrons increases as they are away from the nucleus. The probability of finding the 1s electron may be higher at a_0 but the energy is not. The probability density of finding the electron is not zero at any place in the atom. So, the energy may be higher when it is far from a_0 .

20. The maximum number of possible oxidation states of actinoids are shown by

- (1) nobelium (No) and lawrencium (Lr) (2*) neptunium (Np) and plutonium (Pu)
- (3) actinium (Ac) and thorium (Th) (4) berkelium (Bk) and californium (Cf)

Sol.

Ac	Th	Pu	U	Np	Pu	Am	Cm	Bk	Cf	Es	Fm	Md	No	Lr
+3		+3	+3	+3	+3	+3	+3	+3	+3	+3	+3	+3	+2	+3
	+4	+4	+4	+4	+4	+4	+4	+4						
		+5	+5	+5	+5	+5								
			+6	+6	+6									
		+6	+7	+7										

∴ Np and Pu has maximum no. of possible oxidation states

21. In an acid-base titration, 0.1 M HCl solution was added to the NaOH solution of unknown strength. Which of the following correctly shows the change of pH of the titration mixture in this experiment?

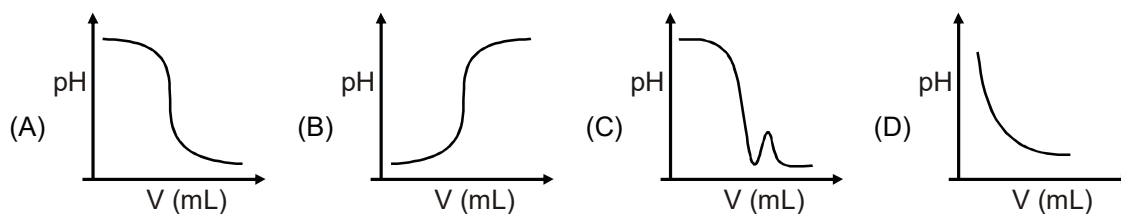

- (1*) (A) (2) (C) (3) (B) (4) (D)

Sol. The nature of the curve is such that the pH change of the reaction becomes larger for very small change in volume of titrant.

22. Among the following species, the diamagnetic molecule is

- (1) NO (2*) CO (3) O₂ (4) B₂

Sol. CO is diamagnetic in nature due to absence of any unpaired electron.

23. During compression of a spring the work done is 10 kJ and 2 kJ escaped to the surroundings as heat. The change in internal energy, (in kJ) is:

- (1) 12 (2) -8 (3*) 8 (4) -12

Sol. Work done on system = +10 kJ

Heat escaped = -2kJ

$$\Delta U = q + w$$

$$= 10 - 2 = 8 \text{ kJ}$$

24. The major product of the following reaction is :

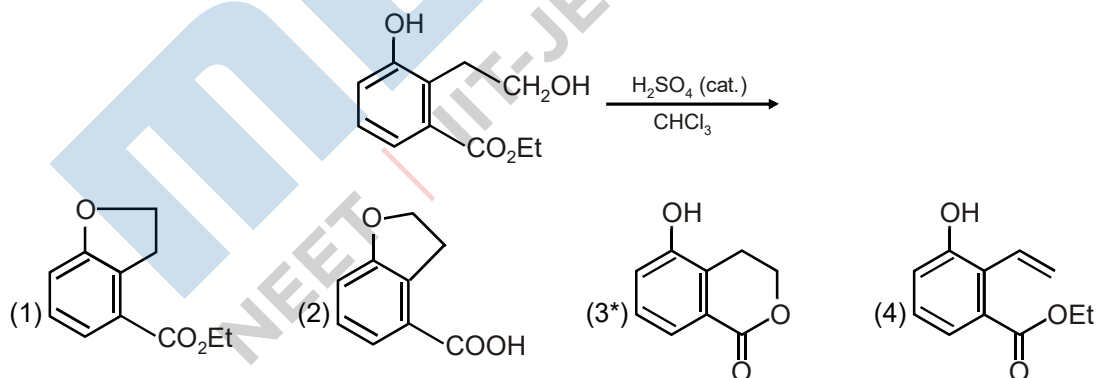

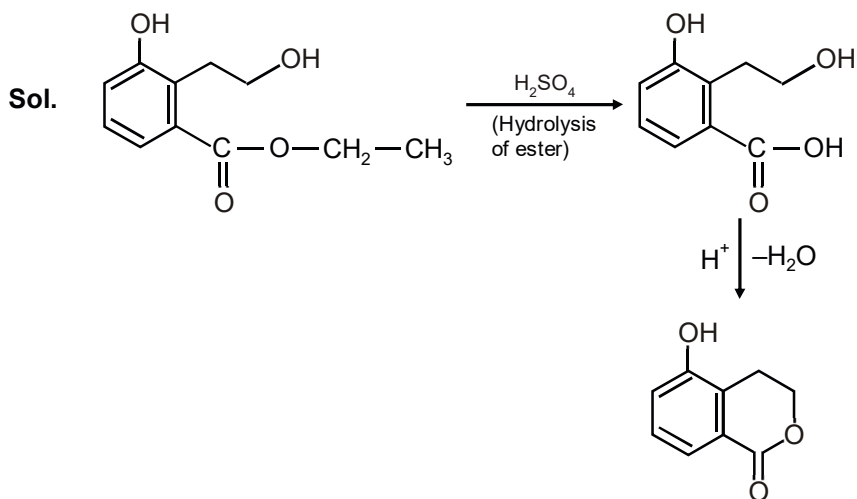

Chloroform is used as solvent in this reaction.

25. The major product A and B for the following reactions are, respectively :

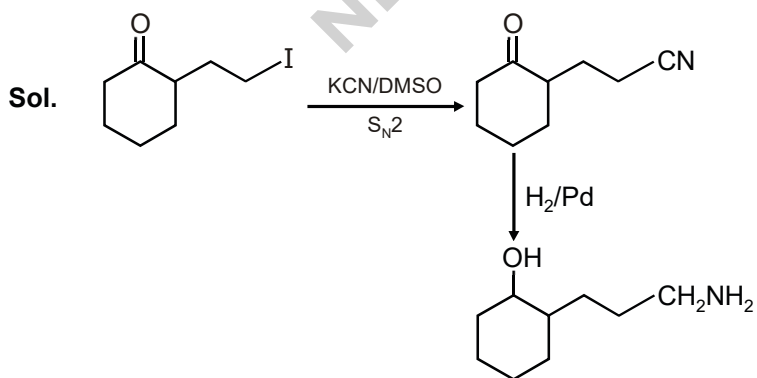
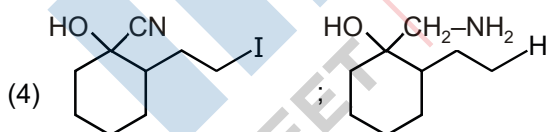
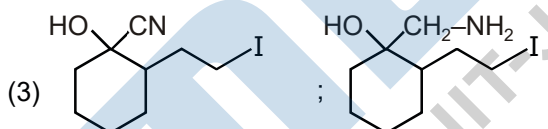
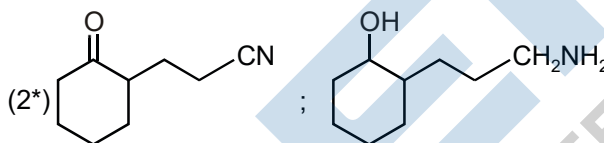
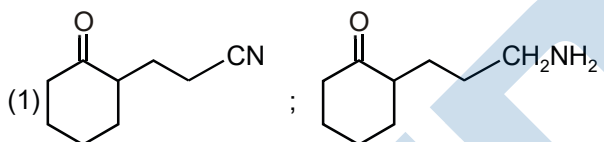
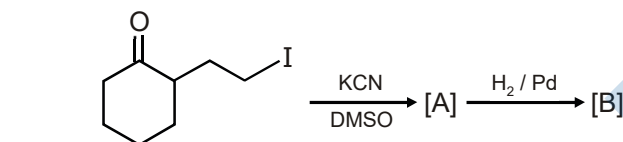

26. The structures of beryllium chloride in the solid state and vapour, phase, respectively, are :
 (1*) chain and dimeric (2) chain and chain (3) dimeric and chain (4) dimeric and dimeric

Sol. Solid state – chain

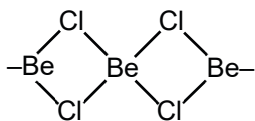

In vapour state dimeric

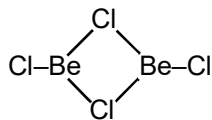

27. The correct statements among I to III regarding group 13 element oxides are,
 (I) Boron trioxide is acidic.
 (II) Oxides of aluminium and gallium are amphoteric.
 (III) Oxides of indium and thallium are basic.
 (1) (II) and (III) only (2*) (I), (II) and (III) (3) (I) and (II) only (4) (I) and (III) only

Sol. B_2O_3 is acidic in nature

Al_2O_3 and Ga_2O_3 are amphoteric

Oxides of In and Tl are basic in nature. Because the metallic character of the elements increases on moving down the group.

28. 10 mL of 1mM surfactant solution forms a monolayer covering 0.24 cm^2 on a polar substrate. If the polar head is approximated as a cube, what is its edge length?
 (1) 2.0 nm (2*) 2.0 pm (3) 0.1 nm (4) 1.0 pm

Sol. Moles = $\frac{MV}{1000} = \frac{10^{-3} \times 10}{1000} = 10^{-5}$ mole

$10^{-5} N_A$ molecules covering area = 0.24 cm^2

$$1 \text{ molecule} \text{---} \text{-----} = \frac{0.24}{10^{-5} N_A} \text{ cm}^2$$

$$\frac{0.24}{10^{-5} \times 6 \times 10^{23}} = a^2$$

$$a^2 = 4 \times 10^{-20} \text{ cm}^2$$

$$a = 2 \times 10^{-10} \text{ cm}$$

$$a = 2 \times 10^{-12} \text{ m}$$

$$a = 2 \text{ pm}$$

29. The layer of atmosphere between 10 km to 50 km above the sea level is called as :

- (1) thermosphere (2) troposphere (3) mesosphere (4*) stratosphere

Sol. Fact based.

30. Which of the following potential energy (PE) diagrams represents the S_N1 reaction?

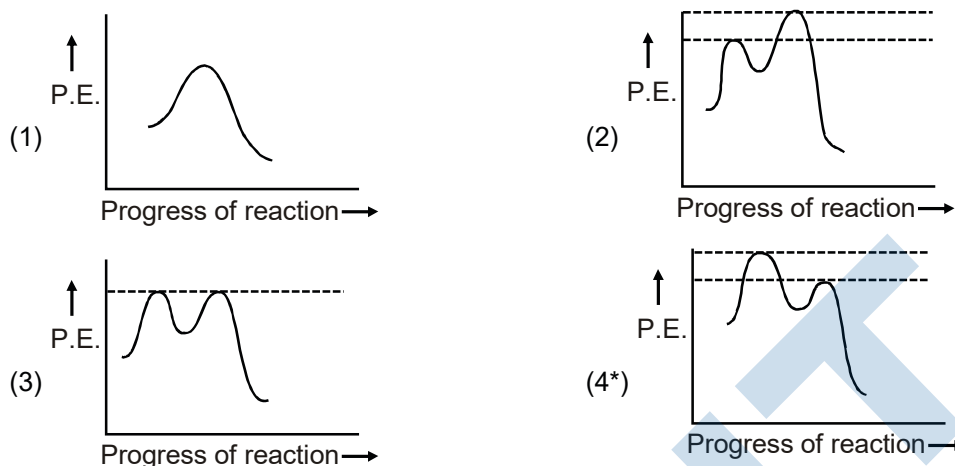

Sol. For S_N1 carbocation is formed.

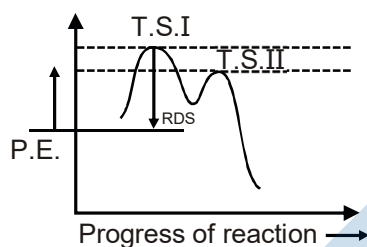

This first transition state should have higher energy than the second transition state. Reaction intermediate is also formed.

also $d = |r_1 - r_2|$

circles touch internally

Equation of common tangent $S_1 - S_2 = 0$

$\Rightarrow 6x + 8y - 20 = 0$

$\Rightarrow 3x + 4y - 10 = 0$

Point $(6, -2)$ satisfy it.

33. The vertices B and C of a ΔABC lie on the line, $\frac{x+2}{3} = \frac{y-1}{0} = \frac{z}{4}$ such that $BC = 5$ units. Then the area (in sq. units) of this triangle, given that the point $A(1, -1, 2)$, is
 (1) $5\sqrt{17}$ (2) 6 (3) $2\sqrt{34}$ (4*) $\sqrt{34}$

Sol. Let any point on given line is

$D(3\lambda - 2, 1, 4\lambda)$

Now $AD \perp BC$

D.R. of BC

$\Rightarrow a_1 = 3, b_1 = 0, c_1 = 4$

D.R. of AD

$\Rightarrow a_2 = 3\lambda - 3, b_2 = 2, c_2 = 4\lambda - 2$

$\Rightarrow a_1 a_2 + b_1 b_2 + c_1 c_2 = 0$

$\Rightarrow 3(3\lambda - 3) + 0 + 4(4\lambda - 2) = 0$

$25\lambda = 17$

$\Rightarrow \lambda = \frac{17}{25}$

Co-ordinate of point D

$(\frac{1}{25}, 1, \frac{68}{25})$

$AD = \sqrt{\frac{576}{625} + 4 + \frac{324}{25}} = \frac{2}{5}\sqrt{34}$

Area of $\Delta ABC = \frac{1}{2} \times BC \times AD$

$= \frac{1}{2} \times 5 \times \frac{2}{5} \sqrt{34} = \sqrt{34}$

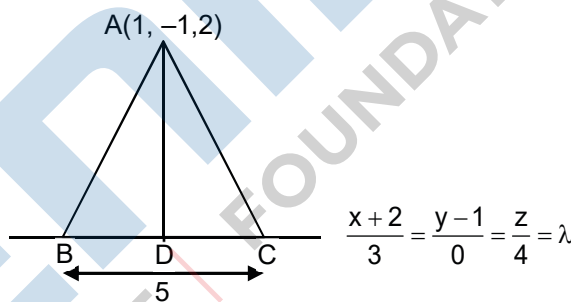

34. The value of $\sin 10^\circ \sin 30^\circ \sin 50^\circ \sin 70^\circ$ is

- (1) $\frac{1}{18}$ (2) $\frac{1}{32}$ (3) $\frac{1}{36}$ (4*) $\frac{1}{16}$

Sol. $\sin 10^\circ \sin 30^\circ \sin 50^\circ \sin 70^\circ$
 $= \sin 10^\circ \sin 30^\circ \sin 50^\circ \sin 70^\circ$
 $= \sin 30^\circ \{ \sin 10^\circ \sin(60^\circ - 10^\circ) \sin(60^\circ + 10^\circ) \}$
 $= \sin 30^\circ \left\{ \frac{1}{4} \sin 3(10^\circ) \right\}$
 $= \frac{1}{16}$

35. If the function $f(x) = \begin{cases} a|\pi - x| + 1, & x \leq 5 \\ b|x - \pi| + 3, & x > 5 \end{cases}$ is continuous at $x = 5$, then the value of $a - b$ is

- (1) $\frac{2}{\pi - 5}$ (2) $\frac{2}{\pi + 5}$ (3*) $\frac{2}{5 - \pi}$ (4) $\frac{-2}{\pi + 5}$

Sol. $f(x) = \begin{cases} a|\pi - x| + 1, & x \leq 5 \\ b|x - \pi| + 3, & x > 5 \end{cases}$

Contributes at $x = 5$

\therefore L.H.L. = R.H.L = $f(5)$

$\Rightarrow b|\pi - 5| + 3 = a|\pi - 5| + 1$

$\Rightarrow -b(\pi - 5) + 3 = -a(5 - \pi) + 1$

$\Rightarrow (a - b)(\pi - 5) = -2$

$\Rightarrow a - b = \frac{-2}{\pi - 5} = \frac{2}{5 - \pi}$

36. If $\int e^{\sec x} (\sec x \tan x f(x) + (\sec x \tan x + \sec^2 x)) dx = e^{\sec x} f(x) + C$, then a possible choice of $f(x)$ is

- (1) $x \sec x + \tan x + \frac{1}{2}$ (2) $\sec x - \tan x - \frac{1}{2}$
 (3*) $\sec x + \tan x + \frac{1}{2}$ (4) $\sec x + \tan x - \frac{1}{2}$

Sol. $\int e^{\sec x} (\sec x + \tan x f(x) + (\sec x \tan x + \sec^2 x)) dx = e^{\sec x} f(x) + C$

Diff. both side w.r.t.x

$= e^{\sec x} (\sec x + \tan x + f(x) + (\sec x \tan x + \sec^2 x))$

$= e^{\sec x} \cdot \sec x \tan x f(x) + e^{\sec x} f(x)$

$\Rightarrow f'(x) = \sec^2 x + \tan x \sec x$

$\Rightarrow f(x) = \tan x + \sec x + C$

37. If $\cos x \frac{dy}{dx} - y \sin x = 6x$, $\left(0 < x < \frac{\pi}{2}\right)$ and $y\left(\frac{\pi}{3}\right) = 0$, then $y\left(\frac{\pi}{6}\right)$ is equal to

(1) $-\frac{\pi^2}{2}$

(2) $-\frac{\pi^2}{4\sqrt{3}}$

(3*) $-\frac{\pi^2}{2\sqrt{3}}$

(4) $\frac{\pi^2}{2\sqrt{3}}$

Sol. $\cos x \frac{dy}{dx} - y \sin x = 6x$

$\Rightarrow \frac{dy}{dx} - y \tan x = 6x \sec x$

$= e^{-\int \tan x dx} = e^{-\log_e \sec x} = \frac{1}{\sec x}$

: solution of equation

$\Rightarrow y \cdot \frac{1}{\sec x} = \int 6x \sec x \cdot \frac{1}{\sec x} dx$

$\Rightarrow \frac{y}{\sec x} = 3x^2 + x \dots\dots\dots(1)$

given $y\left(\frac{\pi}{3}\right) = 0$

So, $0 = 3\frac{\pi^2}{9} + C$

$\Rightarrow \frac{y}{\sec x} = 3x^2 - \frac{\pi^2}{3}$

At $x = \frac{\pi}{6}$

$\Rightarrow \frac{\sqrt{3}y}{2} = \frac{3x^2}{36} - \frac{\pi^2}{3}$

$\Rightarrow y = -\frac{\pi^2}{2\sqrt{3}}$

38. If m is chosen in the quadratic equation $(m^2 + 1)x^2 - 3x + (m^2 + 1)^2 = 0$ such that the sum of its roots is greatest, then the absolute difference of the cubes of its roots is

(1) $10\sqrt{5}$

(2) $8\sqrt{3}$

(3*) $8\sqrt{5}$

(4) $4\sqrt{3}$

Sol. $(m^2 + 1)x^2 - 3x + (m^2 + 1)^2 = 0$

$\Rightarrow \alpha + \beta = \frac{3}{m^2 + 1}$

$\alpha\beta = \frac{(m+1)^2}{m^2 + 1}$

$\because \alpha + \beta$ is maximum

$\because m^2 + 1$ is minimum

$\Rightarrow m = 0$

$\therefore \alpha + \beta = 3$ and $\alpha\beta = 1$

$|\alpha^3 - \beta^3| = |(\alpha - \beta)(\alpha^2 + \alpha\beta + \beta^2)|$

$\left| \sqrt{(\alpha - \beta)^2 - 4\alpha\beta} \{(\alpha + \beta)^2 - \alpha\beta\} \right|$

$= \left| \sqrt{9 - 4} (9 - 1) \right|$

$= 8\sqrt{5}$

39. Let $z \in \mathbb{C}$ be such that $|z| < 1$. If $\omega = \frac{5+3z}{5(1-z)}$, then

(1*) $5 \operatorname{Re}(\omega) > 1$

(2) $5 \operatorname{Im}(\omega) < 1$

(3) $4 \operatorname{Im}(\omega) > 5$

(4) $5 \operatorname{Re}(\omega) > 4$

Sol. $W = \frac{5+3z}{5(1-z)}$

$\Rightarrow 5w - 5wz = 5 + 3z$

$\Rightarrow z = \frac{5w-5}{3+5w}$

Given $|z| < 1$

$\Rightarrow \left| \frac{5w-5}{3+5w} \right| < 1$

$\Rightarrow |5w-5| < |3+5w|$

$\Rightarrow |w-1| < \left| \frac{3}{5} + w \right|$

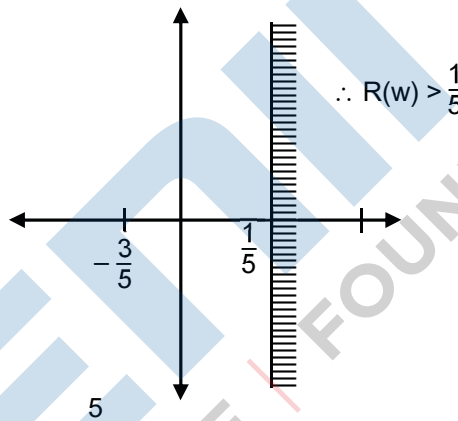

40. If the sum and product of the first three terms in an A.P. are 33 and 1155, respectively, then a value of its 11th term is

(1) -35

(2*) -25

(3) -36

(4) 25

Sol. Let the three numbers in A.P. are $a-d, a, a+d$

Given that $a-d + a + a+d = 33$

$\Rightarrow a = 11$ and $(a+d)(a)(a+d) = 1155$

$\Rightarrow a(a^2-d^2) = 1155$

$\Rightarrow 11(121 - d^2) = 1155$

$\Rightarrow d^2 = 16$

$\Rightarrow d = \pm 4$

If $d = 4$ then first term $a-d = 7$

If $d = -4$ then first term $a-d = 15$

$T_{11} = 7 + 10(4) = 47, T_{11} = 15 + 10(-4) = -25$

and $x - y - 4 = 0 \dots\dots\dots(ii)$

solving (1) and (2)

$$(x - y)^2 = 2x$$

$$\Rightarrow x^2 - 10x + 16 = 0$$

$$\Rightarrow x = 8, 2 \text{ and } y = 4, -2$$

$$A = \int_{-2}^4 \left(y + 4 - \frac{y^2}{2} \right) dy$$

$$A = \left(\frac{y^2}{4} + 4y - \frac{y^3}{6} \right)_{-2}^4$$

$$A = \left(4 + 16 - \frac{64}{6} \right) - \left(1 - 8 + \frac{8}{6} \right) = 18$$

44. If $p \Rightarrow (q \vee r)$ is false, then the truth values of p, q, r are respectively

- (1) T, T, F (2*) T, F, F (3) F, F, F (4) F, T, T

Sol. $p \Rightarrow (q \vee r)$ is false

$$(\because T \Rightarrow F = F)$$

So, $p = T, q = F$ and $r = F$

45. If $f : \mathbb{R} \rightarrow \mathbb{R}$ is a differentiable function and $f(2) = 6$, then $\lim_{x \rightarrow 2} \int_6^{f(x)} \frac{2t}{(x-2)} dt$ is

- (1) $2f'(2)$ (2*) $12f'(2)$ (3) 0 (4) $24f'(2)$

Sol. $\lim_{x \rightarrow \infty} \int_6^{f(x)} \frac{2tdt}{(x-2)} dx$ {given that $f(2) = 6$ }

$\frac{0}{0}$ form, so we use L - Hospital Rule

$$\lim_{x \rightarrow \infty} \frac{f'(x) \cdot 2f(x)}{1}$$

$$= f'(2) \cdot 2f(2)$$

$$= 12f'(2)$$

46. If $f(x) = [x] - \left[\frac{x}{4} \right], x \in \mathbb{R}$, where $[x]$ denotes the greatest integer function, then:

(1) Both $\lim_{x \rightarrow 4^-} f(x)$ and $\lim_{x \rightarrow 4^+} f(x)$ exist but are not equal.

(2) $\lim_{x \rightarrow 4^+} f(x)$ exists but $\lim_{x \rightarrow 4^-} f(x)$ does not exist.

(3*) f is continuous at $x = 4$.

(4) $\lim_{x \rightarrow 4^-} f(x)$ exists but $\lim_{x \rightarrow 4^+} f(x)$ does not exist.

Sol. $f(x) = [x] - \left[\frac{x}{4} \right]$

$$\lim_{x \rightarrow 4^+} f(x) = \lim_{x \rightarrow 4^+} \left([x] - \left[\frac{x}{4} \right] \right) = 4 - 1 = 3$$

$$\lim_{x \rightarrow 4^-} f(x) = \lim_{x \rightarrow 4^-} \left([x] - \left[\frac{x}{4} \right] \right) = 3 - 0 = 3$$

$$F(4) = 3$$

\therefore Continuous at $x = 4$

47. The sum of the series $1 + 2 \times 3 + 3 \times 5 + 4 \times 7 + \dots$ upto 11th term is:

(1*) 946

(2) 945

(3) 916

(4) 915

Sol. $S = 1 + 2 \times 3 + 3 \times 5 + 4 \times 7 + \dots +$ upto 11 terms

n^{th} term of the series is $T_n = n(2n-1)$

$$\Rightarrow S = \sum_{n=1}^{11} T_n = \sum_{n=1}^{11} (2n^2 - n)$$

$$\Rightarrow S_n = \frac{2n(n+1)(2n+1)}{6} - \frac{n(n+1)}{2}$$

Put $n = 11$

$$\Rightarrow S_{11} = \frac{2(11)(12)(23)}{6} - \frac{11(12)}{2}$$

$$\Rightarrow S_{11} = 946$$

48. The area (in sq. units) of the smaller of the two circles that touch the parabola, $y^2 = 4x$ at the point $(1, 2)$ and the x-axis is:

(1*) $8\pi(3 - 2\sqrt{2})$

(2) $4\pi(3 + \sqrt{2})$

(3) $4\pi(2 - \sqrt{2})$

(4) $8\pi(2 - \sqrt{2})$

Sol. Equation of tangent to the parabola $y^2 = 4x$ at

$$(1, 2) \text{ is } 2y = 4\left(\frac{x+1}{2}\right)$$

$$\Rightarrow y = x + 1$$

Equation of normal $y = -x + 3$

Let centre be $C(3 - r, r)$

$$\text{Now } PC^2 = r^2$$

$$\Rightarrow (3 - r - 1)^2 + (r - 2)^2 = r^2$$

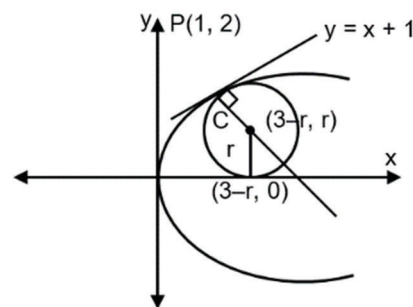

$$\Rightarrow 2(2 - r)^2 = r^2$$

$$\Rightarrow r^2 - 8r + 8 = 0$$

$$\Rightarrow r = 4 \pm 2\sqrt{2}$$

For $r = 4 + 2\sqrt{2}$ ($3 - r < 0$) Not possible

$$\text{So } r = 4 - 2\sqrt{2}$$

$$\text{Area} = \pi r^2 = \pi(16 + 8 - 16\sqrt{2})$$

$$= 8\pi(3 - 2\sqrt{2})$$

49. A water tank has the shape of an inverted right circular cone, whose semi-vertical angle is $\tan^{-1}\left(\frac{1}{2}\right)$.

Water is poured into it at a constant rate of 5 cubic meter per minute. Then the rate (in m/min.), at which the level of water is rising at the instant when the depth of water in the tank is 10m; is:

- (1*) $1/5 \pi$ (2) $1/10 \pi$ (3) $1/15 \pi$ (4) $2/\pi$

Sol. Given $\theta = \tan^{-1}\left(\frac{1}{2}\right)$

$$\Rightarrow \tan\theta = \frac{1}{2} = \frac{r}{h}$$

$$\Rightarrow r = \frac{h}{2}$$

$$V = \frac{1}{3}\pi r^2 h$$

$$V = \frac{1}{3}\pi \frac{h^3}{4}$$

$$\frac{dv}{dt} = \frac{\pi}{12}(3h^2) \frac{dh}{dt}$$

$$5 = \frac{\pi}{4}(100) \frac{dh}{dt} \Rightarrow \frac{dh}{dt} = \frac{1}{5\pi}$$

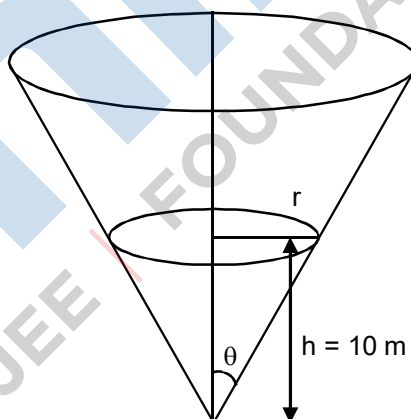

50. Some identical balls are arranged in rows to form an equilateral triangle. The first row consists of one ball, the second row consists of two balls and so on. If 99 more identical balls are added to the total number of balls used in forming the equilateral triangle, then all these balls can be arranged in a square whose each side contains exactly 2 balls less than the number of balls each side of the triangle contains. Then the number of balls used to form the equilateral triangle is:

- (1) 225 (2) 157 (3*) 190 (4) 262

Sol. $\frac{n(n+1)}{2} + 99 = (n-2)^2$

$$\Rightarrow n^2 + n + 198 = 2n^2 - 8n + 8$$

$$\Rightarrow n^2 - 9n - 190 = 0$$

$$\Rightarrow (n - 19)(n + 10) = 0$$

$$\Rightarrow n = 19$$

$$\therefore \text{Number of balls is } \frac{18 \times 20}{2} = 190$$

51. If the tangent to the parabola $y^2 = x$ at a point (α, β) , $(\beta > 0)$ is also a tangent to the ellipse, $x^2 + 2y^2 = 1$, then α is equal to:

(1) $\sqrt{2} - 1$

(2*) $\sqrt{2} + 1$

(3) $2\sqrt{2} - 1$

(4) $2\sqrt{2} + 1$

Sol. Equation of tangent to the parabola $y^2 = x$

At (α, β) is $T = 0$

$$y\beta = \frac{x + \alpha}{2}$$

$$\Rightarrow y\beta = \frac{x + \beta^2}{2} (\because \beta^2 = \alpha)$$

$$\Rightarrow y = \frac{1}{2\beta}x + \frac{\beta}{2}$$

$$\left(m = \frac{1}{2\beta}, c = \frac{\beta}{2} \right)$$

This is also a tangent to ellipse $x^2 + 2y^2 = 1$

$$\therefore C = \pm \sqrt{a^2m^2 + b^2}$$

$$\Rightarrow \frac{\beta}{2} = \pm \sqrt{\frac{1}{4\beta^2} + \frac{1}{2}}$$

$$\Rightarrow \frac{\beta^2}{4} = \frac{1}{4\beta^2} + \frac{1}{2}$$

$$\Rightarrow \beta^4 - 2\beta^2 - 1 = 0$$

$$\Rightarrow (\beta^2 - 1) = 2$$

$$\Rightarrow \beta^2 - 1 = \sqrt{2}$$

$$\Rightarrow \beta^2 = \sqrt{2} + 1$$

$$\alpha = \beta^2 = \sqrt{2} + 1$$

52. If a unit vector \vec{a} makes angles $\pi/3$ with \hat{i} , $\pi/4$ with \hat{j} and $\theta \in (0, \pi)$ with \hat{k} , then a value of θ is:

(1) $\frac{\pi}{4}$

(2) $\frac{5\pi}{6}$

(3) $\frac{5\pi}{12}$

(4*) $\frac{2\pi}{3}$

Sol. $\cos^2 \alpha + \cos^2 \beta + \cos^2 \gamma = 1$

$$\Rightarrow \frac{1}{4} + \frac{1}{2} + \cos^2 \gamma = 1$$

$$\Rightarrow \cos^2 \gamma = 1 - \frac{3}{4} = \frac{1}{4}$$

$$\Rightarrow \cos \gamma = \pm \frac{1}{2}$$

$$\Rightarrow \gamma = \frac{\pi}{3} \text{ or } \frac{2\pi}{3}$$

53. If the two lines $x + (a-1)y = 1$ and $2x + a^2y = 1$ ($a \in \mathbb{R} - \{0, 1\}$) are perpendicular, then the distance of their point of intersection from the origin is:

(1) $\frac{\sqrt{2}}{5}$

(2*) $\frac{\sqrt{2}}{5}$

(3) $\frac{2}{5}$

(4) $\frac{2}{\sqrt{5}}$

Sol. Two lines are perpendicular

$$\therefore m_1 m_2 = -1$$

$$\Rightarrow \left(\frac{-1}{a-1}\right)\left(\frac{-2}{a^2}\right) = -1$$

$$\Rightarrow a^3 - a^2 + 2 = 0$$

$$\therefore a = -1$$

So lines are $\left. \begin{array}{l} L_1 : x - 2y + 1 = 0 \\ L_2 : 2x + y - 1 = 0 \end{array} \right\}$

Solving these equation we get point of intersection

$$P\left(\frac{1}{5}, \frac{3}{6}\right)$$

Now distance of P from origin

$$OP = \sqrt{\frac{1}{25} + \frac{9}{25}} = \frac{\sqrt{2}}{5}$$

54. If some three consecutive coefficients in the binomial expansion of $(x + 1)^n$ in powers of x are in the ratio 2 : 15 : 70, then the average of these three coefficients is

(1) 227

(2*) 232

(3) 625

(4) 964

Sol. Given: $\frac{{}^n C_{r-1}}{{}^n C_r} = \frac{2}{15} \Rightarrow \frac{r}{n-r+1} = \frac{2}{15}$

$$\Rightarrow 15r = 2n - 2r + 2$$

$$\Rightarrow 17r = 2n + 2 \dots\dots\dots(1)$$

also given $\frac{{}^nC_{r-1}}{{}^nC_{r+1}} = \frac{15}{70} \Rightarrow \frac{r+1}{n-r} = \frac{3}{14}$

$\Rightarrow 3n - 3r = 14r + 14$

$\Rightarrow 17r = 2n - 14 \dots\dots\dots(2)$

Solving (1) and (2)

$n = 16, r = 2$

Average of coefficient = $\frac{{}^{16}C_1 + {}^{16}C_2 + {}^{16}C_3}{3}$

$= \frac{16 + 120 + 560}{3}$

$= 232$

55. The value of the integral $\int_0^1 x \cot^{-1}(1 - x^2 + x^4) dx$ is

(1) $\frac{\pi}{2} - \frac{1}{2} \log_e 2$

(2*) $\frac{\pi}{4} - \frac{1}{2} \log_e 2$

(3) $\frac{\pi}{2} - \log_e 2$

(4) $\frac{\pi}{4} - \log_e 2$

Sol. $I = \int_0^1 x \cot^{-1}(1 - x^2 + x^4) dx$

$I = \int_0^1 x \tan^{-1}\left(\frac{1}{1 - x^2 + x^4}\right) dx$

$I = \int_0^1 x \tan^{-1}\left\{\frac{x^2 - (x^2 - 1)}{1 + x^2(x^2 - 1)}\right\} dx$

$I = \int_0^1 \{x \tan^{-1} x^2 - \tan^{-1}(x^2 - 1)\} dx$

Let $x^2 = t \Rightarrow 2x dx = dt$

$I = \frac{1}{2} \int_0^1 \{\tan^{-1} t - \tan^{-1}(t - 1)\} dt$

$= \frac{1}{2} \int_0^1 \tan^{-1} t dt - \frac{1}{2} \int_0^1 \tan^{-1}(t - 1) dt$

$= \frac{1}{2} \int_0^1 \tan^{-1} t dt - \frac{1}{2} \int_0^1 \tan^{-1}(-t) dt$

$= \frac{1}{2} \int_0^1 \tan^{-1} t dt + \frac{1}{2} \int_0^1 \tan^{-1}(t) dt$

$= \int_0^1 \tan^{-1}(t) dt$

$= (t \tan^{-1} t)_0^1 - \int_0^1 \frac{t}{1+t^2} dt$

$$= \left(\frac{\pi}{4}\right) - \frac{1}{2} \left[\log(1+t^2) \right]_0^1$$

$$= \left(\frac{\pi}{4}\right) - \frac{1}{2} \log_e^2$$

56. Two poles standing on a horizontal ground are of heights 5 m and 10 m respectively. The line joining their tops makes an angle of 15° with the ground. Then the distance (in m) between the poles, is

- (1) $\frac{5}{2}(2 + \sqrt{3})$ (2*) $5(2 + \sqrt{3})$ (3) $5(\sqrt{3} + 1)$
 (4) $10(\sqrt{3} - 1)$

Sol. In $\triangle ABC \Rightarrow \tan 15^\circ = \frac{5}{x}$

$$\Rightarrow 2 - \sqrt{3} = \frac{5}{x}$$

$$\Rightarrow x = 5(2 + \sqrt{3})$$

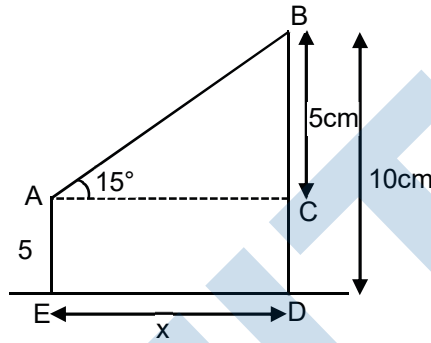

57. Let P be the plane, which contains the line of intersection of the planes, $x + y + z - 6 = 0$ and $2x + 3y + z + 5 = 0$ and it is perpendicular to the xy-plane. Then the distance of the point $(0, 0, 256)$ from P is equal to

- (1) $17 / \sqrt{5}$ (2*) $11 / \sqrt{5}$ (3) $205 \sqrt{5}$ (4) $63 \sqrt{5}$

Sol. Equation of plane $P_1 + \lambda P_2 = 0$

$$(x + y + z - 6) + \lambda(2x + 3y + z + 5) = 0$$

$$\Rightarrow x(1+2\lambda) + y(1 + 3\lambda) + z(1+\lambda) - 6 + 5\lambda = 0$$

This plane is \perp to xy - plane

$$\therefore 1 + \lambda = 0$$

So, equation of plane

$$-x - 2y - 11 = 0$$

$$\Rightarrow x + 2y + 11 = 0$$

distance of the point $(0, 0, 256)$ from this plane.

$$= \frac{|0 + 0 + 11|}{\sqrt{1+4}} = \frac{11}{\sqrt{5}}$$

58. The mean and the median of the following ten numbers in increasing order 10, 22, 26, 29, 34, x, 42, 67,

70, y are 42 and 35 respectively, then $\frac{y}{x}$ is equal to

- (1) $8/3$ (2) $9/4$ (3*) $7/3$ (4) $7/2$

Sol. mean = 42

$$\Rightarrow \frac{10+22+26+29+34+x+42+67+70+y}{10} = 45$$

$$\Rightarrow x + y = 120 \quad \dots\dots\dots(1)$$

and median = 35

$$\Rightarrow \frac{34+x}{2} = 35 \Rightarrow x = 36$$

From (i) $y = 84$

$$\frac{y}{x} = \frac{84}{36} = \frac{7}{3}$$

59. A rectangle is inscribed in a circle with a diameter lying along the line $3y = x + 7$. If the two adjacent vertices of the rectangle are $(-8, 5)$ and $(6, 5)$, then the area of the rectangle (in sq. units) is
 (1*) 84 (2) 56 (3) 72 (4) 98

Sol. Let vertex C is $(6, k)$ then centre of circle

$$\left(-1, \frac{5+k}{2}\right)$$

It lies on diameter $3y = x + 7$

$$\Rightarrow 3\left(\frac{5+k}{2}\right) = -1+7$$

$$\Rightarrow k = -1$$

So, $AB = 14$ and $BC = 6$

$$\text{Area} = 14 \times 6 = 84$$

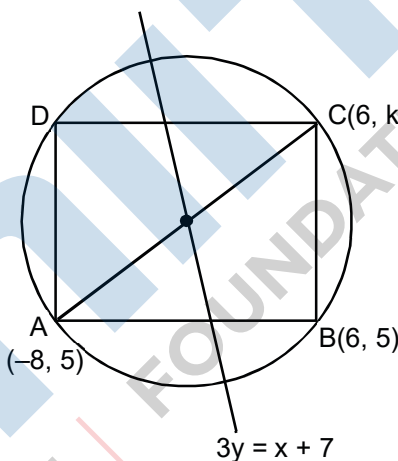

60. The total number of matrices $A = \begin{pmatrix} 0 & 2y & 1 \\ 2x & y & -1 \\ 2x & -y & 1 \end{pmatrix}, (x, y \in \mathbb{R}, x \neq y)$ for which $A^T A = 3I_3$ is
 (1) 2 (2) 3 (3*) 4 (4) 6

Sol. $A^T A = 3I_3$

$$\Rightarrow \begin{vmatrix} 0 & 2x & 2x \\ 2y & y & -y \\ 1 & -1 & 1 \end{vmatrix} \begin{vmatrix} 0 & 2y & 1 \\ 2x & y & -1 \\ 2x & -y & 1 \end{vmatrix} = \begin{vmatrix} 3 & 0 & 0 \\ 0 & 3 & 0 \\ 0 & 0 & 3 \end{vmatrix}$$

$$\Rightarrow \begin{vmatrix} 8x^2 & 0 & 0 \\ 0 & 6y^2 & 0 \\ 0 & 0 & 3 \end{vmatrix} = \begin{vmatrix} 3 & 0 & 0 \\ 0 & 3 & 0 \\ 0 & 0 & 3 \end{vmatrix}$$

$$\Rightarrow 8x^2 = 3 \Rightarrow x = \pm\sqrt{\frac{3}{8}}$$

$$\Rightarrow 6y^2 = 3 \Rightarrow y = \pm\sqrt{\frac{1}{2}}$$

4 matrices are possible

PART-C-PHYSICS

61. A moving coil galvanometer has a coil with 175 turns and area 1 cm^2 . It uses a torsion band of torsion constant 10^{-6} N-m/rad . The coil is placed in a magnetic field B parallel to its plane. The coil deflects by 1° for a current of 1 mA . The value of B (in Tesla) is approximately :-

- (1) 10^{-1} (2*) 10^{-3} (3) 10^{-4} (4) 10^{-2}

Sol. $\tau = \vec{M} \times \vec{B}$

$C\theta = i N A B$

$10^{-6} \times \frac{\pi}{180} = 10^{-3} \times 10^{-4} \times 175 \times B$

$B = 10^{-3} \text{ Tesla}$

62. The logic gate equivalent to the given logic circuit is :

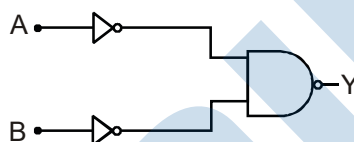

- (1) AND (2) NOR (3) NAND (4*) OR

Sol. Truth table can be formed as

A	B	Equivalent
0	0	0
0	1	1
1	0	1
1	1	1

Hence the equivalent is "OR" gate.

63. The resistance of a galvanometer is 50 ohm and the maximum current which can be passed through it is 0.002 A . What resistance must be connected to it in order to convert it into an ammeter of range $0 - 0.5 \text{ A}$?

- (1) 0.002 ohm (2) 0.5 ohm (3*) 0.2 ohm (4) 0.02 ohm

Sol. Since shunt resistance is connected in parallel with galvanometer, both will have same voltage drop.

$(0.002) (R_G) = (0.5 - 0.002) (r_s)$

$\Rightarrow r_s \approx 0.2 \Omega$

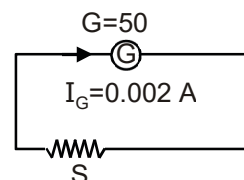

64. The physical sizes of the transmitter and receiver antenna in a communication system are :

- (1) proportional to carrier frequency
 (2) inversely proportional to modulation frequency

- (3*) inversely proportional to carrier frequency
- (4) independent of both carrier and modulation frequency

Sol. The physical size of antenna of receiver and transmitter both are inversely proportional to carrier frequency.

65. The area of a square is 5.29 cm^2 . The area of 7 such squares taking into account the significant figures is

- (1*) 37.0 cm^2
- (2) 37 cm^2
- (3) 37.03 cm^2
- (4) 37.030 cm^2

Sol. Total Area = $A_1 + A_2 + \dots + A_7$
 = $A + A + \dots + 7 \text{ times}$
 = 37.03 m^2

Addition of 7 terms all having 2 terms beyond decimal, so final answer must have 2 terms beyond decimal (as per rules of significant digits)

66. A wedge of mass $M = 4m$ lies on a frictionless plane. A particle of mass m approaches the wedge with speed v . There is no friction between the particle and the plane or between the particle and the wedge. The maximum height climbed by the particle on the wedge is given by :

- (1) $\frac{v^2}{2g}$
- (2*) $\frac{2v^2}{5g}$
- (3) $\frac{v^2}{g}$
- (4) $\frac{2v^2}{7g}$

Sol. Let mass attains height 'h' on wedge and at that time, both attain velocity v_f

Conservation of momentum:

$$mv = (m + 4m)V_f \dots \dots \dots (A)$$

COE:

$$\frac{1}{2}mv^2 = \frac{1}{2}(m + 4m)V_f^2 + mgh \dots \dots \dots (B)$$

From (A) and (B)

$$h = \frac{2V^2}{5g}$$

67. A thin smooth rod of length L and mass M is rotating freely with angular speed ω_0 about an axis perpendicular to the rod and passing through its center. Two beads of mass m and negligible size are at the center of the rod initially. The beads are free to slide along the rod. The angular speed of the system, when the beads reach the opposite ends of the rod, will be :

- (1) $\frac{M\omega_0}{M + 3m}$
- (2) $\frac{M\omega_0}{M + 2m}$
- (3) $\frac{M\omega_0}{M + m}$
- (4*) $\frac{M\omega_0}{M + 6m}$

Sol. Conservation of angular momentum about rotation axes:

$$L_i = L_f$$

$$\left(\frac{m\ell^2}{12}\right)\omega_0 = \left[\frac{M\ell^2}{12} + 2\left(m\left(\frac{\ell}{2}\right)^2\right)\right]\omega_f$$

$$\Rightarrow \omega_f = \left(\frac{M}{M+6m}\right)\omega_0$$

68. A massless spring ($k = 800 \text{ N/m}$), attached with a mass (500 g) is completely immersed in 1 kg of water. The spring is stretched by 2 cm and released so that it starts vibrating. What would be the order of magnitude of the change in the temperature of water when the vibrations stop completely? (Assume that the water container and spring receive negligible heat and specific heat of mass = 400 J/kg K, specific heat of water = 4184 J/kg K)

- (1) 10^{-3} K (2) 10^{-4} K (3) 10^{-1} K (4*) 10^{-5} K

Sol. By law of conservation of energy

$$\frac{1}{2}kx^2 = (m_1s_1 + m_2s_2)\Delta T$$

$$\Delta T = \frac{16 \times 10^{-2}}{4384} = 3.65 \times 10^{-5}$$

69. The specific heats, C_p and C_v of a gas of diatomic molecules, A, are given (in units of $\text{J mol}^{-1} \text{ K}^{-1}$) by 29 and 22, respectively. Another gas of diatomic molecules, B, has the corresponding values 30 and 21. If they are treated as ideal gases, then :

- (1) A has one vibrational mode and B has two
 (2) A is rigid but B has a vibrational mode
 (3) Both A and B have a vibrational mode each
 (4*) A has a vibrational mode but B has none

Sol. For A:

$$\frac{C_p}{C_v} = \gamma = 1 + \frac{2}{f} = \frac{29}{22}$$

It gives $f = 6.3 \approx 6$ (3 translational, 2 rotational and 1 vibrational)

For B:

$$\frac{C_p}{C_v} = \gamma = 1 + \frac{2}{f} = \frac{30}{21}$$

$$\Rightarrow f = 4.67$$

$\Rightarrow \approx 5$ (3 translational, 2 rotational, no vibrational)

70. Two materials having coefficients of thermal conductivity '3K' and 'K' and thickness 'd' and '3d', respectively, are joined to form a slab as shown in the figure. The temperatures of the outer surfaces are θ_2 and θ_1 respectively, ($\theta_2 > \theta_1$). The temperature at the interface is :

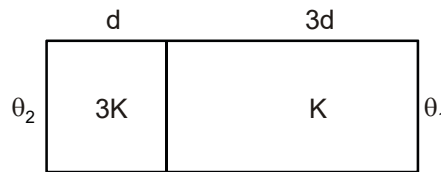

- (1) $\frac{\theta_1}{3} + \frac{2\theta_2}{3}$ (2) $\frac{\theta_2 + \theta_1}{2}$ (3*) $\frac{\theta_1}{10} + \frac{9\theta_2}{10}$ (4) $\frac{\theta_1}{6} + \frac{5\theta_2}{6}$

Sol. At steady state:

$$\left(\frac{\Delta q}{\Delta t}\right)_1 = \left(\frac{\Delta q}{\Delta t}\right)_2$$

$$\frac{3kA(\theta_2 - \theta)}{d} = \frac{kA(\theta - \theta_1)}{3d}$$

$$\Rightarrow \theta = \frac{\theta_1 + 9\theta_2}{10}$$

71. Moment of inertia of a body about a given axis is 1.5 kg m^2 . Initially the body is at rest. In order to produce a rotational kinetic energy of 1200 J, the angular acceleration of 20 rad/s^2 must be applied about the axis for a duration of :

- (1) 5s (2) 2.5 s (3*) 2s (4) 3s

Sol. $KE = \frac{1}{2} I\omega^2 = 1200$ (given)

$$\Rightarrow \omega = 40 \text{ rad/s}$$

$$\omega = \omega_0 + \alpha t$$

$$40 = 0 + (20) t$$

$$\Rightarrow t = 2 \text{ sec.}$$

72. Four point charges $-q, +q, +q$ and $-q$ are placed on y-axis at $y = -2d, y = -d, y = +d$ and $y = +2d$, respectively. The magnitude of the electric field E at a point on the x-axis at $x = D$, with $D \gg d$, will behave as :

- (1) $E \propto \frac{1}{D}$ (2) $E \propto \frac{1}{D^3}$ (3) $E \propto \frac{1}{D^2}$ (4*) $E \propto \frac{1}{D^4}$

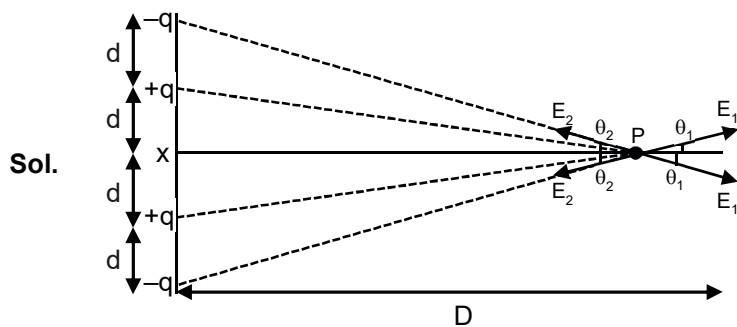

Electric field at p = $2E_1 \cos\theta_1 - 2E_2 \cos\theta_2$

$$= \frac{2Kq}{(d^2 + D^2)} \times \frac{D}{(d^2 + D^2)} - \frac{2Kq}{[(2d)^2 + D^2]} \times \frac{D}{[(2d)^2 + D^2]^{1/2}}$$

$$= 2KqD [(d^2 + D^2)^{-3/2} - (4d^2 + D^2)^{-3/2}]$$

$$= \frac{2KqD}{D^3} \left[\left(1 + \frac{d^2}{D^2}\right)^{-3/2} - \left(1 + \frac{4d^2}{2D^2}\right)^{-3/2} \right]$$

Applying binomial approximation $\because d \ll D$

$$= \frac{2KqD}{D^3} \left[1 - \frac{3d^2}{2D^2} - \left(1 + \frac{3 \times 4d^2}{2D^2}\right) \right]$$

$$= \frac{2KqD}{D^3} \left[\frac{12d^2}{2D^2} - \frac{3d^2}{2D^2} \right]$$

$$= \frac{9Kqd^2}{D^4}$$

73. A convex lens of focal length 20 cm produces images of the same magnification 2 when an object is kept at two distances x_1 and x_2 ($x_1 > x_2$) from the lens. The ratio of x_1 and x_2 is :

- (1) 4 : 3 (2) 2 : 1 (3*) 3 : 1 (4) 5 : 3

Sol. Magnification is 2

If image is real, $x_1 = \frac{3f}{2}$

If image is virtual, $x_2 = \frac{f}{2}$

$$\frac{x_1}{x_2} = 3 : 1$$

74. Two cars A and B are moving away from each other in opposite directions. Both the cars are moving with a speed of 20 ms^{-1} with respect to the ground. If an observer in car A detects a frequency 2000 Hz of the sound coming from car B, what is the natural frequency of the sound source in car B?

(speed of sound in air = 340 ms^{-1})

- (1) 2150 Hz (2) 2300 Hz (3) 2060 Hz (4*) 2250 Hz

Sol. Doppler effect;

$$f = \left(\frac{v + u_o}{v - u_s} \right) (f_0) \quad 2000 = \left(\frac{340 + (-20)}{340 - (-20)} \right) (f_0)$$

$$F_0 = 2250 \text{ Hz}$$

75. A test particle is moving in a circular orbit in the gravitational field produced by a mass density $\rho(r) = \frac{K}{r^2}$

. Identify the correct relation between the radius R of the particle's orbit and its period T:

- (1) TR is constant (2*) T/R is a constant (3) T/R^2 is a constant (4) T^2/R^3 is a constant

Sol. For circular motion of particle:

$$\frac{mV^2}{r} = mE$$

$$= m \left(\frac{GM}{r^2} \right)$$

$$\text{Where } M = \int_0^r (4\pi x^2 dx) \left(\frac{k}{x^2} \right)$$

$$= 4\pi kr$$

$$\Rightarrow \frac{mv^2}{r} = m \left(\frac{G(4\pi k)}{r} \right)$$

$$\Rightarrow V = \text{constant}$$

$$T = \frac{2\pi R}{V}$$

$$\Rightarrow \frac{T}{R} = \text{Constant}$$

76. Two coils 'P' and 'Q' are separated by some distance. When a current of 3A flows through coil 'P', a magnetic flux of 10^{-3} Wb passes through 'Q'. No current is passed through 'Q' when no current passes through 'P' and a current of 2A passes through 'Q', the flux through 'P' is :

- (1) 3.67×10^{-3} Wb (2) 3.67×10^{-4} Wb (3*) 6.67×10^{-4} Wb (4) 6.67×10^{-3} Wb

Sol. Mutual induction

$$\phi_q = MI_p$$

$$10^{-3} = M(3)$$

$$\Rightarrow M = \frac{1}{3} \times 10^{-3}$$

$$\phi_p = MI_q$$

$$\Rightarrow \phi_p = 6.67 \times 10^{-4} \text{ Wb}$$

77. A very long solenoid of radius R is carrying current $I(t) = kte^{-\alpha t}$ ($k > 0$), as a function of time ($t \geq 0$). Counter clockwise current is taken to be positive. A circular conducting coil of radius $2R$ is placed in the equatorial plane of the solenoid and concentric with the solenoid. The current induced in the outer coil is correctly depicted, as a function of time, by :

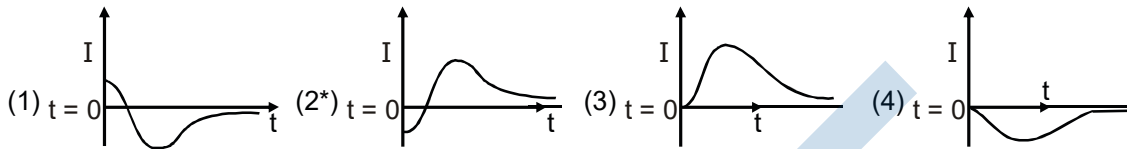

Sol.
$$\varepsilon = -\frac{d\phi}{dt} = -\frac{d}{dt}(\mu_0 n I)(\pi R^2)$$

$$= -(-\mu_0 n \pi R^2) \frac{dI}{dt}$$

$$= -\mu_0 n \pi R^2 \frac{d(kt e^{-\alpha t})}{dt}$$

$$= -C (t(e^{-\alpha t})(-\alpha) + e^{-\alpha t}) \quad (C \rightarrow \text{constant})$$

$$= -C (e^{-\alpha t})(1 - \alpha t)$$

Clearly, at $t = 0$

Induced current $\neq 0$

Also, apply Lenz law to find correct option.

78. The position vector of a particle changes with time according to the relation $\vec{r}(t) = 15t^2\hat{i} + (4 - 20t^2)\hat{j}$. What is the magnitude of the acceleration at $t = 1$?

(1) 100

(2) 40

(3*) 50

(4) 25

Sol.
$$\vec{r} = (15t^2)\hat{i} + (4 - 20t^2)\hat{j}$$

$$\vec{v} = \frac{d\vec{r}}{dt} = (30t)\hat{i} - (40t)\hat{j}$$

$$\vec{a} = \frac{d\vec{v}}{dt} = (30)\hat{i} - (40)\hat{j}$$

$$|\vec{a}| = 50$$

79. A thin convex lens L (refractive index = 1.5) is placed on a plane mirror M . When a pin is placed at A , such that $OA = 18$ cm, its real inverted image is formed at A itself, as shown in figure. When a liquid of

refractive index μ , is put between the lens and the mirror, The pin has to be moved to A', such that $OA' = 27$ cm, to get its inverted real image at A' itself. The value of μ , will be

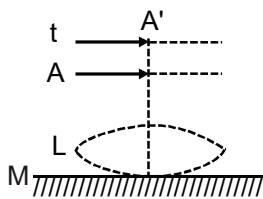

- (1*) $\frac{4}{3}$ (2) $\sqrt{2}$ (3) $\frac{3}{2}$ (4) $\sqrt{3}$

Sol. For image to form at object itself, rays must retrace their path back to object. Hence must incident on mirror normally.

Case 1: Object will be at focus of lens

$$\frac{1}{f} = (\mu - 1) \left(\frac{1}{R} - \frac{1}{-R} \right) = \frac{1}{-18}$$

$$\Rightarrow R = 18 \text{ cm}$$

Case 2: Refraction at 1st surface:

$$\frac{1}{-27} - \frac{1.5}{V_1} = \frac{1 - 1.5}{R} \quad \dots\dots\dots(i)$$

2nd refraction :

$$\frac{1.5}{V_1} - \frac{\mu}{\infty} = \frac{1.5 - \mu}{-R} \quad \dots\dots\dots(ii)$$

Form (i) and (ii)

$$\mu = \frac{4}{3}$$

80. 50 W/m^2 energy density of sunlight is normally incident on the surface of a solar panel. Some part of incident energy (25%) is reflected from the surface and the rest is absorbed. The force exerted on 1m^2 surface area will be close to ($c = 3 \times 10^8 \text{ m/s}$) :-

- (1) $10 \times 10^{-8} \text{ N}$ (2*) $20 \times 10^{-8} \text{ N}$ (3) $15 \times 10^{-8} \text{ N}$ (4) $35 \times 10^{-8} \text{ N}$

Sol. Radiation pressure for 100% reflection = $\frac{2I}{C}$

Radiation pressure for 0% reflection = $\frac{I}{C}$

$$\begin{aligned} \text{Hence, in given case, radiation pressure} &= (0.25) \left(\frac{2I}{C} \right) + (0.75) \left(\frac{I}{C} \right) \\ &= (1.25) \left(\frac{I}{C} \right) \end{aligned}$$

$$\begin{aligned} \text{Force} &= P \times (\text{Area}) \\ &= 20.83 \times 10^{-8} \text{ N} \end{aligned}$$

81. In a conductor, if the number of conduction electrons per unit volume is $8.5 \times 10^{28} \text{ m}^{-3}$ and mean free time is 25 fs (femto second). It's approximate resistivity is: ($m_e = 9.1 \times 10^{-31} \text{ kg}$)
- (1) $10^{-6} \Omega\text{m}$ (2*) $10^{-8} \Omega\text{m}$ (3) $10^{-5} \Omega\text{m}$ (4) $10^{-7} \Omega\text{m}$

Sol.
$$\rho = \frac{2m}{ne^2\tau}$$

$$= 3.34 \times 10^{-8} \Omega\text{m}$$

82. Diameter of the objective lens of a telescope is 250 cm. For light of wavelength 600 nm. coming from a distant object, the limit of resolution of the telescope is close to :
- (1) $1.5 \times 10^{-7} \text{ rad}$ (2*) $3.0 \times 10^{-7} \text{ rad}$ (3) $2.0 \times 10^{-7} \text{ rad}$ (4) $4.5 \times 10^{-7} \text{ rad}$

Sol. Limit of resolution $= \frac{1.22\lambda}{d}$

$$= \frac{1.22 \times 600 \times 10^{-9}}{250 \times 10^{-2}}$$

$$= 2.9 \times 10^{-7} \text{ rad.}$$

83. A particle 'P' is formed due to a completely inelastic collision of particles 'x' and 'y' having de-Broglie wavelengths ' λ_x ' and ' λ_y ' respectively. If x and y were moving in opposite directions, then the de-Broglie wavelength of 'P' is:

(1*) $\frac{\lambda_x \lambda_y}{|\lambda_x - \lambda_y|}$ (2) $\lambda_x - \lambda_y$ (3) $\frac{\lambda_x \lambda_y}{\lambda_x + \lambda_y}$ (4) $\lambda_x + \lambda_y$

Sol. Conservation of momentum

$$\vec{p}_x + \vec{p}_y = \vec{p}_{\text{final}}$$

$$m_x v_x - m_y v_y = (m_x + m_y) V$$

$$\frac{h}{\lambda_x} - \frac{h}{\lambda_y} = \frac{h}{\lambda}$$

$$\Rightarrow \lambda = \frac{\lambda_x \lambda_y}{|\lambda_x - \lambda_y|}$$

84. The parallel combination of two air filled parallel plate capacitors of capacitance C and nC is connected to a battery of voltage, V. When the capacitors are fully charged, the battery is removed and after that a dielectric material of dielectric constant K is placed between the two plates of the first capacitor. The new potential difference of the combined system is :

(1) $\frac{nV}{K+n}$

(2*) $\frac{(n+1)V}{(K+n)}$

(3) $\frac{V}{K+n}$

(4) V

Sol.

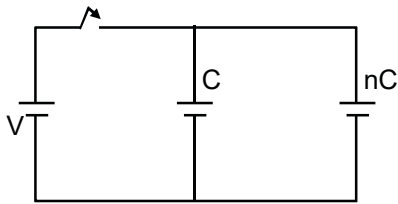

After fully charging, battery is disconnected.

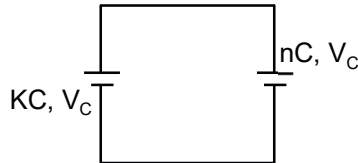
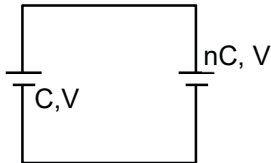

Total charge of the system = $CV + nCV$

= $(n + 1)CV$

After the insertion of dielectric of constant K

New potential (common)

$$V_c = \frac{\text{Total charge}}{\text{Total charge}}$$

$$= \frac{(n+1)CV}{KC+nC} = \frac{(n+1)V}{K+n}$$

85. A string 2.0 m long and fixed at its ends is driven by a 240 Hz vibrator. The string vibrates in its third harmonic mode. The speed of the wave and its fundamental frequency is

- (1*) 320 m/s, 80 Hz (2) 180 m/s, 120 Hz (3) 180 m/s, 80 Hz (4) 320 m/s, 120 Hz

Sol. We have

$$f = \frac{nv}{2l}$$

$$240 = \frac{3 \times v}{2 \times 2}$$

$$\Rightarrow v = 320 \text{ m/s}$$

$$\text{Fundamental frequency} = \frac{v}{2l} = 80 \text{ Hz.}$$

86. A wooden block floating in a bucket of water has $\frac{4}{5}$ of its volume submerged. When certain amount of an oil is poured into the bucket, it is found that the block is just under the oil surface with half of its volume under water and half in oil. The density of oil relative to that of water is :

- (1) 0.5 (2) 0.8 (3) 0.7 (4*) 0.6

Sol. In 1st situation

$$V_b \rho_b g = V_s \rho_w g$$

$$\frac{V_s}{V_b} = \frac{\rho_b}{\rho_w} = \frac{4}{5} \quad \dots(i)$$

Here V_b is volume of block

V_s is submerged volume of block

ρ_b is density of block

ρ_w is density of water & Let ρ_0 is density of oil

Finally in equilibrium condition

$$V_b \rho_b g = \frac{V_b}{2} \rho_0 g + \frac{V_b}{2} \rho_w g$$

$$2\rho_b = \rho_0 + \rho_w$$

$$\Rightarrow \frac{\rho_0}{\rho_w} = \frac{3}{5} = 0.6$$

87. A metal wire of resistance 3Ω is elongated to make a uniform wire of double its previous length. This new wire is now bent and the ends joined to make a circle. If two points on this circle make an angle 60° at the centre, the equivalent resistance between these two points will be :

- (1) $\frac{5}{2}\Omega$ (2*) $\frac{5}{3}\Omega$ (3) $\frac{12}{5}\Omega$ (4) $\frac{7}{2}\Omega$

Sol. $R = \frac{\rho \ell}{A} = \frac{\rho \ell}{(V/\ell)} = \frac{\rho \ell^2}{V}$ ($V \rightarrow$ Volume of wire)

$$\Rightarrow \text{Final resistance} = 3 \times (2)^2 = 12 \Omega$$

$$R_{eq} = 2 \Omega \parallel 10 \Omega$$

$$= \frac{5}{3} \Omega$$

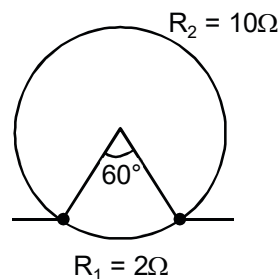

88. The position of a particle as a function of time t , is given by $x(t) = at + bt^2 - ct^3$ where a , b and c are constants. When the particle attains zero acceleration, then its velocity will be :

- (1) $a + \frac{b^2}{2c}$ (2*) $a + \frac{b^2}{3c}$ (3) $a + \frac{b^2}{4c}$ (4) $a + \frac{b^2}{c}$

Sol. $x = at + bt^2 - ct^3$

$$V = \frac{dx}{dt} = a + 2bt - 3ct^2$$

$$a = \frac{dv}{dt} = 2b - 6ct$$

Put acceleration = 0

$$\Rightarrow t = \frac{b}{3c}$$

Find V at $\Rightarrow t = \frac{b}{3c}$

$$V = a + \frac{b^2}{3c}$$

89. A particle of mass 'm' is moving with speed '2v' and collides with a mass '2m' moving with speed 'v' in the same direction. After collision, the first mass is stopped completely while the second one splits into two particles each of mass 'm', which move at angle 45° with respect to the original direction. The speed of each of the moving particle will be :

- (1) $v / (2\sqrt{2})$ (2) $v / \sqrt{2}$ (3*) $2\sqrt{2}v$ (4) $\sqrt{2}v$

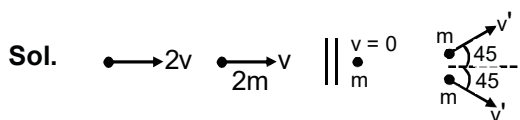

Linear momentum conservation

$$M 2v + 2m v = m \times 0 + m \frac{v'}{\sqrt{2}} \times 2$$

$$v' = 2\sqrt{2} v.$$

90. A He⁺ ion is in its first excited state. Its ionization energy is :
- (1) 54.40 eV (2*) 13.60 eV (3) 48.36 eV (4) 6.04 eV

Sol. T.E. = $-(13.6) \left(\frac{Z^2}{n^2} \right) \text{eV}$

$$Z = n = 2$$

$$\Rightarrow \text{Ionisation energy} = -\text{T.E.} \\ = 13.6 \text{ eV}$$